

BAILI

BAILI

BAILI 百利冷柜
REFRIGERATOR 创于1991
——百里挑一 百利冷柜——

BAILI



本资料产品只适用于中国大陆销售和使用的，经过仔细核对，力求准确。本公司保留更改产品设计与规格的权利，产品图片如与实物有轻微差别，请以实物为准，如有变更，恕不另行通知。广东利臣制冷有限公司拥有本手册最终解释权。

骑士
CAVALIER
卧式展示
直冷



骑士系列 卧式展示冷柜

HORIZONTAL SHOWCASE FREEZER

CAVALIER

产品特性 Product Features

温控器

Temperature controller

操作简易, 工作状态一目了然

Easy to operate, working condition is clear at a glance



铝合金边框

Aluminum alloy frame

大圆角设计, 超宽铝合金边框

Large round corner design with superwide aluminum alloy frame



钢化镀膜玻璃门

Toughened coated glass door

钢化镀膜玻璃门, 减少热量流失, 保温节能防凝露

Heat reflecting glass, anti condensation, durable and energy saving



发泡层

Foam layer

70MM超厚发泡层, 更好地锁住温度

70MM foam layer for better cold reserving

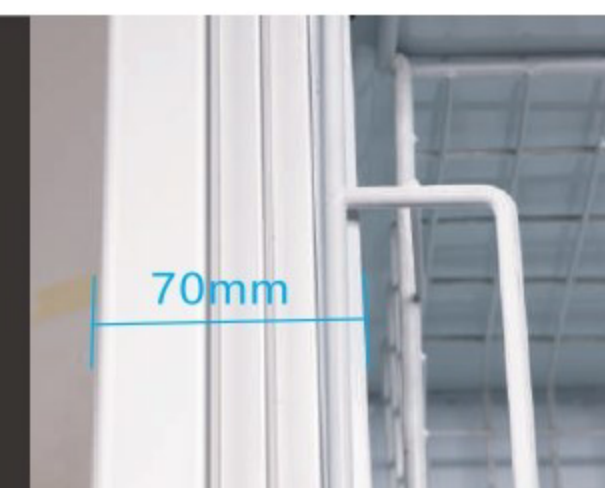

脚轮

Wheels

双实心脚轮设计, 承重能力更强

Double solid wheels design with great load capacity



防凝露管

Anti-condensation tube

暗藏式防凝露管, 低温下也能保持门头滑动流畅

Concealed anti-condensation tube along the frame to make sure of no frost



立体散热

Three-dimensional heat dissipation

有效防止灰尘进入机组
Effectively prevent dust from entering the unit



CAVALIER 骑士系列平面卧式冷柜

骑士系列弧面卧式冷柜 CAVALIER

10°C~-25°C

■ 双冷凝器



型号 MODEL	WD-300	WD-370	WD-450
功率 INPUT POWER	190W	250W	310W
有效容积 VALIDITY CAPACITY	280L	350L	420L
制冷系统 SYSTEM	直冷 DIRECT COOLING	直冷 DIRECT COOLING	直冷 DIRECT COOLING
温度 TEMP	10°C~-25°C	10°C~-25°C	10°C~-25°C
外观尺寸 E.DIM	1056x671x825mm	1266x671x825mm	1476x671x825mm
包装尺寸 P.DIM	1115x760x865mm	1325x760x865mm	1535x760x865mm
净重 NET	66KG	72KG	79KG
毛重 GROSS	76KG	85KG	93KG
制冷剂 REF.	R290	R290	R290

10°C~-25°C

■ 双冷凝器



型号 MODEL	WD-268Y	WD-338Y	WD-398Y
功率 INPUT POWER	190W	250W	310W
有效容积 VALIDITY CAPACITY	248L	318L	378L
制冷系统 SYSTEM	直冷 DIRECT COOLING	直冷 DIRECT COOLING	直冷 DIRECT COOLING
温度 TEMP	10°C~-25°C	10°C~-25°C	10°C~-25°C
外观尺寸 E.DIM	1056x671x825mm	1266x671x825mm	1476x671x825mm
包装尺寸 P.DIM	1115x760x865mm	1325x760x865mm	1535x760x865mm
净重 NET	65KG	70KG	76KG
毛重 GROSS	75KG	83KG	90KG
制冷剂 REF.	R290	R290	R290

10°C~-25°C

■ 双冷凝器



型号 MODEL	WD-530	WD-610
功率 INPUT POWER	400W	480W
有效容积 VALIDITY CAPACITY	510L	590L
制冷系统 SYSTEM	直冷 DIRECT COOLING	直冷 DIRECT COOLING
温度 TEMP	10°C~-25°C	10°C~-25°C
外观尺寸 E.DIM	1686x671x825mm	1896x671x825mm
包装尺寸 P.DIM	1745x760x865mm	1955x760x865mm
净重 NET	84KG	93KG
毛重 GROSS	102KG	111KG
制冷剂 REF.	R290	R290

10°C~-25°C

■ 双冷凝器



型号 MODEL	WD-458Y	WD-518Y
功率 INPUT POWER	400W	480W
有效容积 VALIDITY CAPACITY	438L	498L
制冷系统 SYSTEM	直冷 DIRECT COOLING	直冷 DIRECT COOLING
温度 TEMP	10°C~-25°C	10°C~-25°C
外观尺寸 E.DIM	1686x671x825mm	1896x671x825mm
包装尺寸 P.DIM	1745x760x865mm	1955x760x865mm
净重 NET	82KG	88KG
毛重 GROSS	97KG	105KG
制冷剂 REF.	R290	R290

水蜜桃
PEACH
顶盖门
直冷

水蜜桃系列
顶盖门卧式冷柜
TOP OPEN CHEST FREEZER
PEACH

产品特性 Product Features

门把手

Door handle

符合人体工学的门把手设计, 握感舒适, 实用美观

Ergonomic door handle design, comfortable grip, practical and beautiful



多级位门铰

Multi-stage door hinge

门体开合可随意定位, 方便取物

Flexible hinge makes it more convenient to open and close



彩涂内胆

Color coated liner

采用彩涂内胆, 美观耐用

Adopt color-coated liner



机械式温控器

Mechanical temperature controller

操作自如, 工作状态一目了然

Easy operation and clear working status



门锁

Door lock

安全门锁设计, 防止随意开启

Safety lock design, prevent discretionary opening



实心脚轮

Solid casters

实心脚轮设计, 承重能力更强

Solid wheels design with great load capacity



防尘网

Dust net

有效防止灰尘进入机组

Effectively prevent dust from entering the unit



制冷系统

Refrigeration System

双重冷凝系统, 制冷快, 更省电

Double condensation system, fast cooling, use less electricity



10°C~-25°C

10°C~-25°C



型号 MODEL	BC/BD-230 (D)	BC/BD-320	BC/BD-420
功率 INPUT POWER	127W	176W	203W
有效容积 VALIDITY CAPACITY	230L	320L	420L
制冷系统 SYSTEM	直冷 DIRECT COOLING	直冷 DIRECT COOLING	直冷 DIRECT COOLING
温度 TEMP	10°C~-25°C	10°C~-25°C	10°C~-25°C
外观尺寸 E.DIM	1140x655x898 mm	1080x745x898 mm	1350x745x898 mm
包装尺寸 P.DIM	1210x680x940 mm	1145x775x940 mm	1415x775x940 mm
净重 NET	47KG	51KG	62KG
毛重 GROSS	52KG	57KG	69KG
制冷剂 REF.	R290	R290	R290

10°C~-25°C

■ 双冷凝器



型号 MODEL	BC/BD-520	BC/BD-620
功率 INPUT POWER	246W	350W
有效容积 VALIDITY CAPACITY	520L	620L
制冷系统 SYSTEM	直冷 DIRECT COOLING	直冷 DIRECT COOLING
温度 TEMP	10°C~-25°C	10°C~-25°C
外观尺寸 E.DIM	1620x745x898 mm	1880x745x898 mm
包装尺寸 P.DIM	1685x775x940 mm	1945x775x940 mm
净重 NET	70KG	79KG
毛重 GROSS	78KG	87KG
制冷剂 REF.	R290	R290



型号 MODEL	BC/BD-820	BC/BD-1020	BC/BD-1520
功率 INPUT POWER	400W	460W	500W
有效容积 VALIDITY CAPACITY	820L	1020L	1300L
制冷系统 SYSTEM	直冷 DIRECT COOLING	直冷 DIRECT COOLING	直冷 DIRECT COOLING
温度 TEMP	10°C~-25°C	10°C~-25°C	10°C~-25°C
外观尺寸 E.DIM	2220x815x990 mm	2680x815x990 mm	2450x990x1045 mm
包装尺寸 P.DIM	2285x845x1010 mm	2745x845x1010 mm	2515x1015x1200 mm
净重 NET	104KG	115KG	150KG
毛重 GROSS	124KG	140KG	175KG
制冷剂 REF.	R290	R290	R290

10°C~-25°C

■ 五面制冷



型号 MODEL	BC/BD-1820	BC/BD-2320
功率 INPUT POWER	600W	700W
有效容积 VALIDITY CAPACITY	1600L	2100L
制冷系统 SYSTEM	直冷 DIRECT COOLING	直冷 DIRECT COOLING
温度 TEMP	10°C~-25°C	10°C~-25°C
外观尺寸 E.DIM	2910x990x1045 mm	3680x990x1045 mm
包装尺寸 P.DIM	2975x1015x1200 mm	3745x1015x1200 mm
净重 NET	180KG	230KG
毛重 GROSS	210KG	255KG
制冷剂 REF.	R290	R290

康乃馨系列

弧面卧式冷柜

ISLAND TYPE REFRIGERATOR

CARNATIONS

产品特性 Product Features

柜体圆角工艺
Round corner frame

圆边框设计有效
减少碰撞的伤害
Humanized round
corner effectively
Avoid accident



半月形拉手
Half-moon handle

符合人体工学设计，
握感舒适，实用美观
Ergonomic design,
comfortable grip,
practical and beautiful



热反射镀膜玻璃
Heat reflective coated glass

热反射镀膜玻璃，减少
热量流失，保温节能防
凝露
Heat reflective coated
glass, anti condensation,
heat preservation and
energy saving

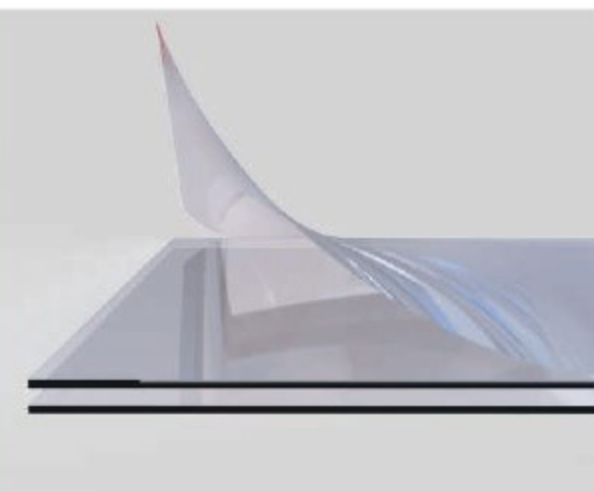

电子温控器
Electronic thermostat

操作自如，工作
状态一目了然
Easy operation and
clear working status



LED灯管
LED Lighting

内箱LED照明设计，
让箱内物品清晰明亮
LED lighting offers a clear
view of inside goods



实心脚轮
Solid casters

实心脚轮设计，
承重能力更强
Solid wheels design with
great load capacity



康乃馨系列弧面卧式冷柜 CARNATIONS

-18°C~-22°C
双冷凝器



型号 MODEL	SD/SC-550	SD/SC-770
功率 INPUT POWER	300W	390W
有效容积 VALIDITY CAPACITY	480L	675L
制冷系统 SYSTEM	直冷 DIRECT COOLING	直冷 DIRECT COOLING
温度 TEMP	-18°C~-22°C	-18°C~-22°C
外观尺寸 E.DIM	1500x755x895 mm	2000x755x895 mm
包装尺寸 P.DIM	1550x805x975 mm	2050x805x975 mm
净重 NET	72KG	93KG
毛重 GROSS	100KG	130KG
制冷剂 REF.	R290	R290

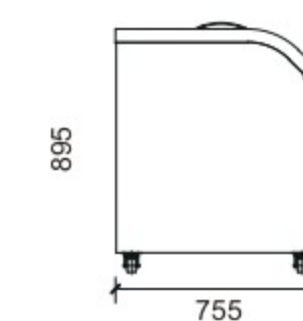
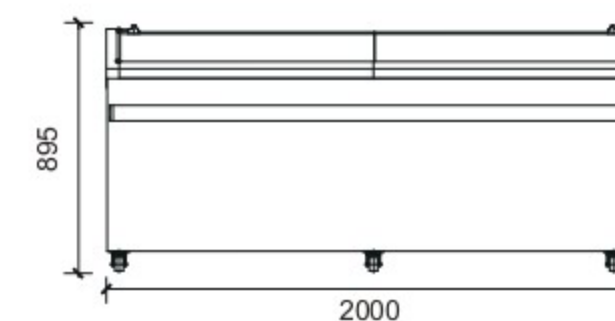
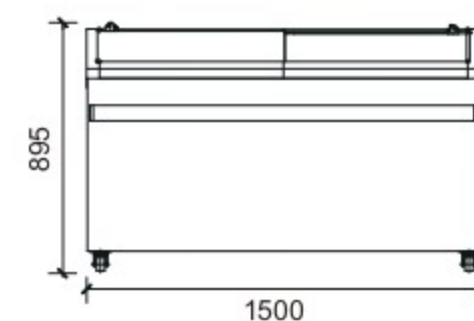

康乃馨
CARNATIONS
岛式冷柜
直冷

康乃馨系列

岛式冷柜

ISLAND TYPE REFRIGERATOR

CARNATIONS

产品特性 Product Features

圆边框设计
Round border design

圆边框设计有效
减少碰撞的伤害
Effectively reduces
collision damage



货篮
Basket

喷涂货篮, 耐用美观
Spray painted basket,
durable and good-
looking



热反射镀膜玻璃
Heat Reflective coated glass

热反射镀膜玻璃, 减少
热量流失, 保温节能防
凝露
Heat Reflective coated glass,
anti condensation, heat
preservation and energy
saving



电子温控器
Electronic thermostat

电子显示温控器, LED
精确调节温度
LED display, adjust
temperature accurately



立体散热
Three-dimensional
heat dissipation

有效防止灰尘进入机组
Effectively prevent dust
from entering the unit



实心脚轮
Solid casters

实心脚轮设计,
承重能力更强
Solid wheels
design with great
load capacity



CARNATIONS 康乃馨系列出口岛式冷柜

-18°C~-25°C



型号 MODEL	SD-530	SD-750	SD-980
功率 INPUT POWER	450W	560W	610W
有效容积 VALIDITY CAPACITY	530L	750L	980L
制冷系统 SYSTEM	直冷 DIRECT COOLING	直冷 DIRECT COOLING	直冷 DIRECT COOLING
温度 TEMP	-18°C~-25°C	-18°C~-25°C	-18°C~-25°C
外观尺寸 E.DIM	1536x936x770 mm	2036x936x770 mm	2536x936x770 mm
包装尺寸 P.DIM	1660x1050x845 mm	2160x1050x845 mm	2660x1050x845 mm
净重 NET	81KG	100KG	140KG
毛重 GROSS	126KG	150KG	200KG
制冷剂 REF.	R290	R290	R290

